

J-CLASS SandHandler

Submersible pumps

TRI-SEAL™
Floating Stage System
U.S. Patent No. 7,290,984





J-CLASS SandHandler

Submersible pumps

The J-Class SandHandler 100mm submersible pump features the new TRI-SEAL floating stage system. This new stage system further improves efficiency and protects against wear when pumping abrasives (sand). All J-Class SandHandler pumps are unconditionally guaranteed against sand locking in abrasive well conditions for one full year.

Features

- Stainless steel hub floats with the impeller maintaining a positive seal
- Phenolic washer provides down-thrust protection
- Celcon® * impeller provides high efficiency performance and abrasion resistance
- Noryl® * diffuser and disc - proven abrasion-resistant material
- Floating stage design allows impeller to float independently
- Removable, spring-loaded check valve on models with 1 1/4" outlet
- Available in seven performance ranges: 20, 30, 40, 70, 90, 150 and 200 l/min
- Ceramic shaft sleeve and rubber discharge bearing protect shaft and eliminate sand wear
- Powered by Franklin Electric corrosion-resistant 100mm submersible motors

Patented impeller hub seal system seals radially and axially to prevent fluid recirculation. Providing high performance in the harshest conditions.

* **Note:** Celcon® is a registered trademark of The Celanese Corporation
Noryl® is a registered trademark of G.E.

TRI-SEAL™ Floating Stage System

U.S. Patent No. 7,290,984

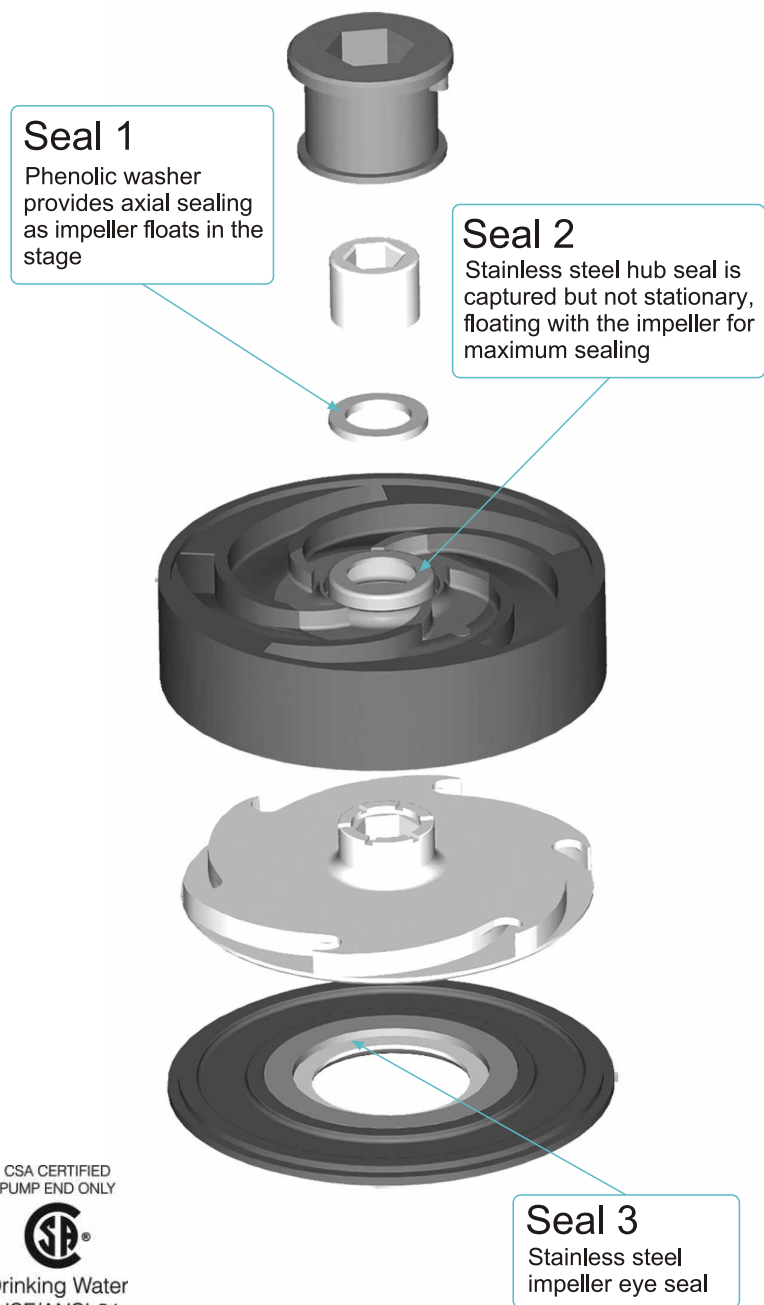

CSA CERTIFIED
PUMP END ONLY



Drinking Water
NSF/ANSI 61

Franklin Electric South Africa (Pty) Limited

Head office and factory
PO Box 8136, Edenglen, 1613, South Africa
13 Engwena Road, Sebenza, Edenvale, 1610
Tel: +27 11 723 6500
Fax: +27 11 609 2417
E-mail: info@franklin-electric.co.za
Website: www.franklin-electric.com

Approved Reseller



Franklin Electric

Contact us for your nearest reseller.

Service and Support - Franklin Electric is the leading manufacturer of world-class pumping system solutions providing the highest quality, availability, service, innovation and value-for-money in the industry. Backed by unsurpassed expertise throughout Africa, these leading brands are ideal for various pumping applications.